

SCM5B37

Non-Linearized Thermocouple Input Modules



Description

Each SCM5B37 non-linearized thermocouple input module provides a single channel of thermocouple input which is filtered, isolated, amplified, and converted to a high-level analog voltage output (Figure 1). This voltage output is logic-switch controlled, allowing these modules to share a common analog bus without the requirement of external multiplexers.

The SCM5B modules are designed with a completely isolated computer side circuit which can be floated to $\pm 50V$ from Power Common, pin 16. This complete isolation means that no connection is required between I/O Common and Power Common for proper operation of the output switch. If desired, the output switch can be turned on continuously by simply connecting pin 22, the Read-Enable pin, to I/O Common, pin 19.

The SCM5B37 can interface to nine industry standard thermocouple types: J, K, T, E, R, S, C, N, and B. Its corresponding output signal operates over a 0V to +5V range. Each module is cold-junction compensated to correct for parasitic thermocouples formed by the thermocouple wire and screw terminals on the mounting backpanel. Upscale open thermocouple detect is provided by an internal pull-up resistor. Downscale indication can be implemented by installing an external $47M\Omega$ resistor, $\pm 20\%$ tolerance, between screw terminals 1 and 3 on the SCMPB01/02/03/04/05/06/07 backpanels.

Signal filtering is accomplished with a six-pole filter which provides 95dB of normal-mode rejection at 60Hz and 90dB at 50Hz. Two poles of this filter are on the field side of the isolation barrier, and the other four are on the computer side.

After the initial field-side filtering, the input signal is chopped by a proprietary chopper circuit. Isolation is provided by transformer coupling, again using a proprietary technique to suppress transmission of common mode spikes or surges. The module is powered from +5VDC, $\pm 5\%$.

► Features

- Interfaces to Types J, K, T, E, R, S, C, N and B Thermocouples
- High-Level Voltage Output
- 1500Vrms Transformer Isolation
- ANSI/IEEE C37.90.1 Transient Protection
- Input Protected to 240VAC Continuous
- 160dB CMR
- 95dB NMR at 60Hz, 90dB at 50Hz
- $\pm 0.03\%$ Accuracy
- $\pm 0.005\%$ Linearity
- $\pm 1\mu V/^{\circ}C$ Drift
- CSA C/US Certified
- CE and ATEX Compliant
- Mix and Match SCM5B Types on Backpanel

A special input circuit on the SCM5B37 modules provides protection against accidental connection of power-line voltages up to 240VAC.

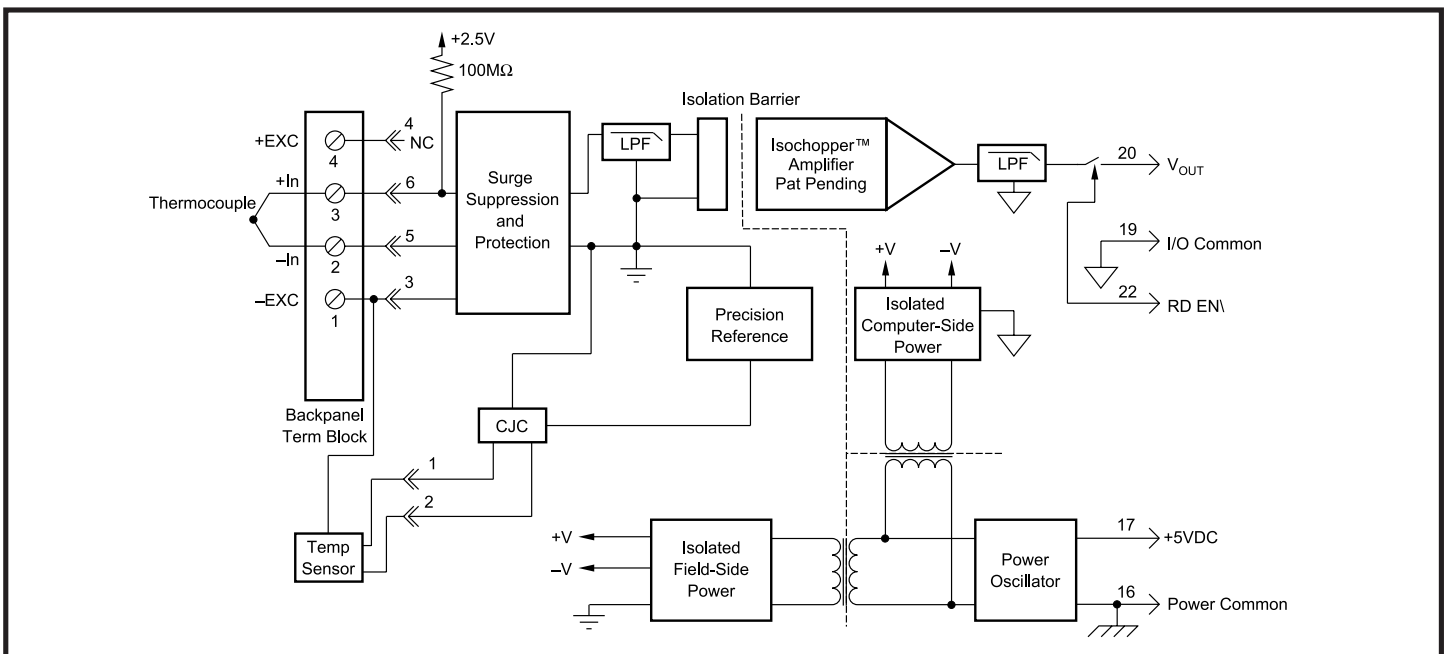

Figure 1: SCM5B37 Block Diagram

Specifications Typical* at $T_A=+25^{\circ}\text{C}$ and +5VDC power

Module	SCM5B37
Input Range	-0.1V to +0.5V
Input Bias Current	-25nA
Input Resistance	
Normal	50M Ω
Power Off	40k Ω
Overload	40k Ω
Input Protection	
Continuous	240Vrms max
Transient	ANSI/IEEE C37.90.1
CMV, Input to Output	
Continuous	1500Vrms max
Transient	ANSI/IEEE C37.90.1
CMR (50Hz or 60Hz)	160dB
NMR	95dB at 60Hz, 90dB at 50Hz
Accuracy	See Ordering Information
Linearity	$\pm 0.005\%$ Span
Stability	
Input Offset	$\pm 1\mu\text{V}/^{\circ}\text{C}^{(2)}$
Output Offset	$\pm 20\mu\text{V}/^{\circ}\text{C}$
Gain	$\pm 25\text{ppm}/^{\circ}\text{C}$
Noise	
Input, 0.1 to 10Hz	0.2 μVrms
Output, 100kHz	200 μVrms
Bandwidth, -3dB	4Hz
Response Time, 90% Span	0.2s
Output Range	See Ordering Information
Output Resistance	50 Ω
Output Protection	Continuous Short to Ground
Output Selection Time (to $\pm 1\text{mV}$ of V_{out})	6 μs at $C_{\text{load}} = 0$ to 2000pF
Output Current Limit	+8mA
Output Enable Control	
Max Logic "0"	+0.8V
Min Logic "1"	+2.4V
Max Logic "1"	+36V
Input Current "0,1"	0.5 μA
Open Input Response	Upscale
Open Input Detection Time	<10s
Cold Junction Compensation	
Accuracy, 25 $^{\circ}\text{C}$	$\pm 0.25^{\circ}\text{C}$
Accuracy, +5 $^{\circ}\text{C}$ to +45 $^{\circ}\text{C}$	$\pm 0.5^{\circ}\text{C}$
Accuracy, -40 $^{\circ}\text{C}$ to +85 $^{\circ}\text{C}$	$\pm 1.25^{\circ}\text{C}$
Power Supply Voltage	+5VDC $\pm 5\%$
Power Supply Current	30mA
Power Supply Sensitivity	$\pm 2\mu\text{V}/\%$ RTI ⁽³⁾
Mechanical Dimensions (h)(w)(d)	2.28" x 2.26" x 0.60" (58mm x 57mm x 15mm)
Environmental	
Operating Temperature Range	-40 $^{\circ}\text{C}$ to +85 $^{\circ}\text{C}$
Storage Temperature Range	-40 $^{\circ}\text{C}$ to +85 $^{\circ}\text{C}$
Relative Humidity	0 to 95% Noncondensing
Emissions EN61000-6-4	ISM, Group 1
Radiated, Conducted	Class A
Immunity EN61000-6-2	ISM, Group 1
RF	Performance A $\pm 0.5\%$ Span Error
ESD, EFT	Performance B

NOTES:

* Contact factory or your local Dataforth sales office for maximum values.

(1) Includes linearity, hysteresis and repeatability. Does not include CJC accuracy.

 (2) This is equivalent to $^{\circ}\text{C}$ as follows: Type J 0.020 $^{\circ}\text{C}/^{\circ}\text{C}$, Types K, T 0.025 $^{\circ}\text{C}/^{\circ}\text{C}$, Type E 0.016 $^{\circ}\text{C}/^{\circ}\text{C}$, Types R, S 0.168 $^{\circ}\text{C}/^{\circ}\text{C}$, Type N 0.037 $^{\circ}\text{C}/^{\circ}\text{C}$, Type C, 0.072 $^{\circ}\text{C}/^{\circ}\text{C}$.

(3) RTI = Referenced to input.

Ordering Information

Model	TC Type [†]	Input Range	Output Range [†]	Accuracy ⁽¹⁾	
SCM5B37J	J	-100 $^{\circ}\text{C}$ to +760 $^{\circ}\text{C}$ (-148 $^{\circ}\text{F}$ to +1400 $^{\circ}\text{F}$)	3, 4	$\pm 0.03\%$	$\pm 0.26^{\circ}\text{C}$
SCM5B37K	K	-100 $^{\circ}\text{C}$ to +1350 $^{\circ}\text{C}$ (-148 $^{\circ}\text{F}$ to +2462 $^{\circ}\text{F}$)	3, 4	$\pm 0.03\%$	$\pm 0.44^{\circ}\text{C}$
SCM5B37T	T	-100 $^{\circ}\text{C}$ to +400 $^{\circ}\text{C}$ (-148 $^{\circ}\text{F}$ to +752 $^{\circ}\text{F}$)	3, 4	$\pm 0.03\%$	$\pm 0.15^{\circ}\text{C}$
SCM5B37E	E	0 $^{\circ}\text{C}$ to +900 $^{\circ}\text{C}$ (+32 $^{\circ}\text{F}$ to +1652 $^{\circ}\text{F}$)	3, 4	$\pm 0.03\%$	$\pm 0.27^{\circ}\text{C}$
SCM5B37R	R	0 $^{\circ}\text{C}$ to +1750 $^{\circ}\text{C}$ (+32 $^{\circ}\text{F}$ to +3182 $^{\circ}\text{F}$)	3, 4	$\pm 0.03\%$	$\pm 0.53^{\circ}\text{C}$
SCM5B37S	S	0 $^{\circ}\text{C}$ to +1750 $^{\circ}\text{C}$ (+32 $^{\circ}\text{F}$ to +3182 $^{\circ}\text{F}$)	3, 4	$\pm 0.03\%$	$\pm 0.53^{\circ}\text{C}$
SCM5B37B	B	0 $^{\circ}\text{C}$ to +1800 $^{\circ}\text{C}$ (+32 $^{\circ}\text{F}$ to +3272 $^{\circ}\text{F}$)	3, 4	$\pm 0.03\%$	$\pm 0.54^{\circ}\text{C}$
SCM5B37C	C	+350 $^{\circ}\text{C}$ to +1300 $^{\circ}\text{C}$ (+662 $^{\circ}\text{F}$ to +2372 $^{\circ}\text{F}$)	3, 4	$\pm 0.03\%$	$\pm 0.29^{\circ}\text{C}$
SCM5B37N	N	-100 $^{\circ}\text{C}$ to +1300 $^{\circ}\text{C}$ (-148 $^{\circ}\text{F}$ to +2372 $^{\circ}\text{F}$)	3, 4	$\pm 0.03\%$	$\pm 0.42^{\circ}\text{C}$

† Thermocouple Alloy Combinations

Standards: DIN IEC 584, ANSI MC96-1-82, JIS C 1602-1981

Type	Material
J	Iron vs. Copper-Nickel
K	Nickel-Chromium vs. Nickel-Aluminum
T	Copper vs. Copper-Nickel
E	Nickel-Chromium vs. Copper-Nickel
R	Platinum-13% Rhodium vs. Platinum
S	Platinum-10% Rhodium vs. Platinum
B	Platinum-30% Rhodium vs. Platinum-6% Rhodium
C	Tungsten-5% Rhenium vs. Tungsten-26% Rhenium
N	Nickel-14.2% Chromium-1.4% Silicon vs. Nickel-4.4% Silicon- 0.1% Magnesium

† Output Ranges Available

Output Range	Part No. Suffix	Example
3. 0V to +5V	NONE	SCM5B37J
4. 0V to +10V	D	SCM5B37JD